

LRB-2023-27

23/00252/FLL – Alterations to dwellinghouse, formation of vehicular access, alterations to rear vehicular access and installation of gates, Morven, Balmoral Road, Rattray, Blairgowrie, PH10 7AF

**PAPERS SUBMITTED
BY THE
APPLICANT**

NOTICE OF REVIEW

UNDER SECTION 43A(8) OF THE TOWN AND COUNTRY PLANNING (SCOTLAND) ACT 1997 (AS AMENDED) IN RESPECT OF DECISIONS ON LOCAL DEVELOPMENTS

THE TOWN AND COUNTRY PLANNING (SCHEMES OF DELEGATION AND LOCAL REVIEW PROCEDURE) (SCOTLAND) REGULATIONS 2013

THE TOWN AND COUNTRY PLANNING (APPEALS) (SCOTLAND) REGULATIONS 2008

IMPORTANT: Please read and follow the guidance notes provided when completing this form. Failure to supply all the relevant information could invalidate your notice of review.

Use **BLOCK CAPITALS** if completing in manuscript

Applicant(s)

Name

Address

Postcode

Contact Telephone 1

Contact Telephone 2

Fax No

E-mail*

Agent (if any)

Name

Address

Postcode

Contact Telephone 1

Contact Telephone 2

Fax No

E-mail*

Mark this box to confirm all contact should be through this representative: X

* Do you agree to correspondence regarding your review being sent by e-mail?

Yes No

Planning authority

Planning authority's application reference number

Site address

Description of proposed development

Date of application

Date of decision (if any)

Note. This notice must be served on the planning authority within three months of the date of the decision notice or from the date of expiry of the period allowed for determining the application.

Nature of application

- 1. Application for planning permission (including householder application)
- 2. Application for planning permission in principle
- 3. Further application (including development that has not yet commenced and where a time limit has been imposed; renewal of planning permission; and/or modification, variation or removal of a planning condition)
- 4. Application for approval of matters specified in conditions

Reasons for seeking review

- 1. Refusal of application by appointed officer
- 2. Failure by appointed officer to determine the application within the period allowed for determination of the application
- 3. Conditions imposed on consent by appointed officer

Review procedure

The Local Review Body will decide on the procedure to be used to determine your review and may at any time during the review process require that further information or representations be made to enable them to determine the review. Further information may be required by one or a combination of procedures, such as: written submissions; the holding of one or more hearing sessions and/or inspecting the land which is the subject of the review case.

Please indicate what procedure (or combination of procedures) you think is most appropriate for the handling of your review. You may tick more than one box if you wish the review to be conducted by a combination of procedures.

- 1. Further written submissions
- 2. One or more hearing sessions
- 3. Site inspection
- 4. Assessment of review documents only, with no further procedure

If you have marked box 1 or 2, please explain here which of the matters (as set out in your statement below) you believe ought to be subject of that procedure, and why you consider further submissions or a hearing are necessary:

NOT APPLICABLE

Site inspection

In the event that the Local Review Body decides to inspect the review site, in your opinion:

Yes No

- | | |
|--|--|
| 1. Can the site be viewed entirely from public land? | <input checked="" type="checkbox"/> <input type="checkbox"/> |
| 2. Is it possible for the site to be accessed safely, and without barriers to entry? | <input checked="" type="checkbox"/> <input type="checkbox"/> |

If there are reasons why you think the Local Review Body would be unable to undertake an unaccompanied site inspection, please explain here:

NOT APPLICABLE

Statement

You must state, in full, why you are seeking a review on your application. Your statement must set out all matters you consider require to be taken into account in determining your review. Note: you may not have a further opportunity to add to your statement of review at a later date. It is therefore essential that you submit with your notice of review, all necessary information and evidence that you rely on and wish the Local Review Body to consider as part of your review.

If the Local Review Body issues a notice requesting further information from any other person or body, you will have a period of 14 days in which to comment on any additional matter which has been raised by that person or body.

State here the reasons for your notice of review and all matters you wish to raise. If necessary, this can be continued or provided in full in a separate document. You may also submit additional documentation with this form.

PLEASE SEE THE ATTACHED SEPARATE DOCUMENTS –

1. NOTICE OF REVIEW APPEAL STATEMENT
2. NOTICE OF REVIEW SUBMISSION APPENDIX

Have you raised any matters which were not before the appointed officer at the time the determination on your application was made? Yes No

If yes, you should explain in the box below, why you are raising new material, why it was not raised with the appointed officer before your application was determined and why you consider it should now be considered in your review.

NOT APPLICABLE

List of documents and evidence

Please provide a list of all supporting documents, materials and evidence which you wish to submit with your notice of review and intend to rely on in support of your review.

NOTICE OF REVIEW APPEAL STATEMENT
 NOTICE OF REVIEW SUBMISSION APPENDIX
 PLANNING APPLICATION DRAWINGS AND SUPPORTING STATEMENT

Note. The planning authority will make a copy of the notice of review, the review documents and any notice of the procedure of the review available for inspection at an office of the planning authority until such time as the review is determined. It may also be available on the planning authority website.

Checklist

Please mark the appropriate boxes to confirm you have provided all supporting documents and evidence relevant to your review:

- Full completion of all parts of this form
- Statement of your reasons for requiring a review
- All documents, materials and evidence which you intend to rely on (e.g. plans and drawings or other documents) which are now the subject of this review.

Note. Where the review relates to a further application e.g. renewal of planning permission or modification, variation or removal of a planning condition or where it relates to an application for approval of matters specified in conditions, it is advisable to provide the application reference number, approved plans and decision notice from that earlier consent.

Declaration

I the applicant/agent [delete as appropriate] hereby serve notice on the planning authority to review the application as set out on this form and in the supporting documents.

Signed



Date

03/08/2023

NOTICE OF REVIEW WRITTEN STATEMENT FOR PLANNING

REFERENCE 23/00252/FLL

Introduction

The Planning application was submitted to undertake various alterations to the property including the formation of accesses.

As mentioned in my Supporting Statement with the Planning Application the following is an extract:

Current Accessibility, Vehicular Parking and Vehicular Access Gates

The current means of access to the property is via the rear external courtyard door directly from Balmoral Road and also from Riverside Road via gates having a width of 2.759m.

From the Balmoral Road entrance there are 2 steps down into the courtyard and from Riverside Road there are several flights of external steps up to the house.

Additionally, the availability of vehicular parking is limited to the public road on Balmoral Road or Riverside Road which involves traversing the several flights of external steps.

In current terms the house would be classed as **'inaccessible'** due to the steps involved.

In order to improve accessibility, it is proposed to increase the existing gate width on Riverside Road to 5m and the formation of a new vehicular access via a new electric sliding gate and a 4m opening in the stone boundary wall on Balmoral Road.

As can be verified on the Google Map all neighbouring properties on the same side of Balmoral Road have vehicular access already installed.

Morven has the added advantage that it is located in the centre of a slight bend in Balmoral Road, thereby providing the longest sight lines in both directions.

In terms of turning and parking at the proposed Balmoral Road entrance there is sufficient space to allow 2 vehicles to park and sufficient space within the existing rear courtyard and to the side to allow entering and exit in a forward gear as indicated on the Proposed Ground Floor Plan.

In similarity with some of the neighbouring properties the applicant is proposing to install mirrors to each side of the opening in the stone wall.

With permission to form the vehicular access from Balmoral Road, this would significantly improve accessibility and also provide inclusivity for wheelchair users. This is a current issue for a relative of the applicant and is the principal reason for the submission of the application.

Reasons for Refusal are as follows: It has not been demonstrated that the vehicular access onto Balmoral Road can achieve satisfactory lines of sight for drivers leaving the property. Accordingly, the access would create an unacceptable adverse impact on road traffic safety. Therefore, the proposal is contrary to Policy 60B(a) of Perth & Kinross Local Development

Plan 2 2019, which requires that development proposals are designed for the safety and convenience of all potential users.

With regards to the specific requirements, I was copied into the following email which relates to the visibility splays although no mention has been made of the document from which it has been extracted:

From: Lachlan MacLean [REDACTED]
Sent: 12 May 2023 08:41
To: Keith Stirton [REDACTED] >
Subject: RE: Morven, Balmoral Road, Rattray Ref: 23/00252/FLL

Dear Keith,

I have taken the opportunity to review the visibility splays that have been provided for the site and can provide the following comments:

- The visibility splay shall be a distance of 43 metre in both directions to the left and right of the property;
- The splay shall be shown from 2.4 metres back from the edge of the public road network;
- The splay shall be drawn to the western side of Balmoral Road, as there are parked cars, vehicle will need to enter the opposing side to pass them.

Can the drawings be amended to show the splay requirements above.

I am currently not in a position to support this application.

Thanks and best regards,
Lachlan

The last bullet point makes compliance with splay requirements even more difficult to achieve.

Comparison of compliance of visibility splays with adjoining public roads and neighbouring properties

Following receipt of the refusal and in preparation of the appeal I surveyed the local adjoining public roads and neighbouring properties to assess how compliant they are with the above visibility splay measurements. **It turns out that none are compliant not even Victoria Street, Balmoral Lane and Middle Road.** Please see the Location Plan of the properties surveyed.

Additionally, the proposal is not the worst-case scenario as the property is at the bend in the road which maximises the visibility in both directions in comparison to the neighbouring properties and roads.

Therefore, the refusal, whilst not being compliant with the above-mentioned visibility splays, appears to be unjust as none of the neighbouring properties and roads are compliant with the measurements requested.

NOTICE OF REVIEW SUBMISSION APPENDIX FOR MORVEN, BALMORAL ROAD, RATTRAY PH10 7AF

List of documents

1. Drawing 7B Existing and proposed elevations to Balmoral Road
2. Drawing 9 Existing and Proposed Block Plan with sight lines
3. Drawing 1 Existing and Proposed Plans
4. Drawing 2 Existing Plans and Elevations
5. Google map
6. Location Plan
7. Location Plan annotated with non-compliant neighbouring properties and road junctions 2.4m back from the public road edge and 43m sight line
8. Notice of Review Appeal Statement
9. Drawing 3B Proposed Ground Floor Plan showing initial sight lines, parking, turning and exit in a forward gear
10. Drawing 10 Section through the stone wall and railings
11. Supporting Statement and photos
12. Velux Conservation roof windows brochure
13. Drawing 5 Wall and gates facing Riverside Road

0 1 2 3 4 5 6 7 8 9 10
 METRES

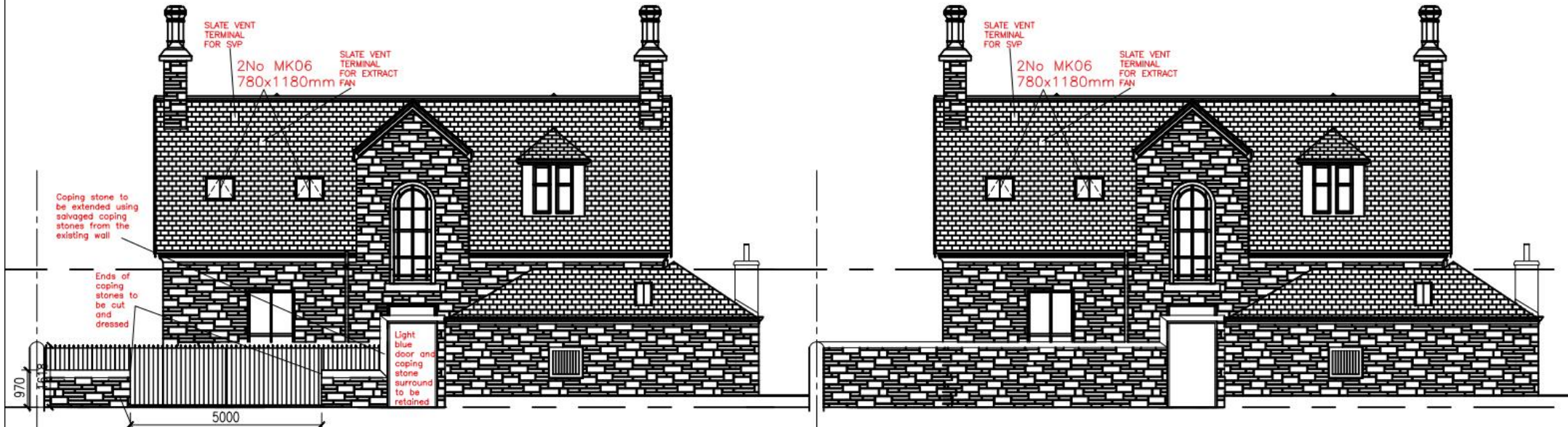

Wall to be rebuilt by a Stonemason, 970mm stone wall including semi-circular stone cope with light blue painted wrought iron railings with spars at 120mm centres up to the height of the existing boundary wall. Stone copings to be drilled with wrought iron railings set 50mm into the crown of the semi-circular coping stones. Existing natural stone and coping stones to be salvaged and re-used and built with lime mortar. Finials to match those on Riverside Road.

PROPOSED EAST ELEVATION
 FROM BALMORAL ROAD WITH FULLY HINGED
 ACCESS GATES

EXISTING WALL WITH PROPOSED EAST
 ELEVATION
 FROM BALMORAL ROAD

PROJECT: PROPOSED ALTERATIONS TO MORVEN, BALMORAL ROAD,
 RATRAY PH10 7AF
 DRAWING REF:EXISTING AND PROPOSED ELEVATIONS OF ACCESS
 GATES TO BALMORAL ROAD
 PAPER SIZE: A1

NORMAN A MACLEOD
 namacleod@aol.com
 Tel: 07884177328

DATE:FEB2023
 SCALE:1TO50
 DRAWING NO:7
 REVISION:B

18/02/2023
MORVEN, BALMORAL ROAD, RATTRAY, PH10 7AF

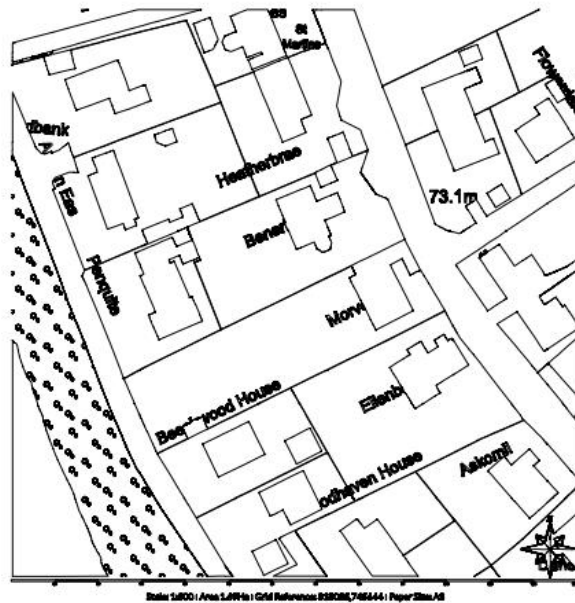

EXISTING BLOCK PLAN 1 TO 500

18/02/2023
MORVEN, BALMORAL ROAD, RATTRAY, PH10 7AF

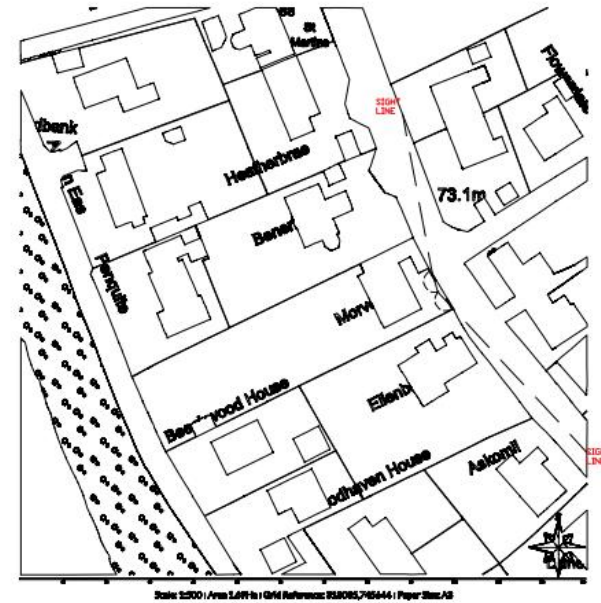

PROPOSED BLOCK PLAN WITH SIGHT LINES 1 TO 500

PROJECT: PROPOSED ALTERATIONS TO MORVEN, BALMORAL ROAD,
RATTRAY PH10 7AF

DRAWING REF: PROPOSED BLOCK PLAN WITH SIGHT LINES

PAPER SIZE: A1

NORMAN A MACLEOD

namacleod@aol.com

Tel: 07884177328

DATE: APRIL 23

SCALE: 1 TO 500

DRAWING NO: 9

REVISION:

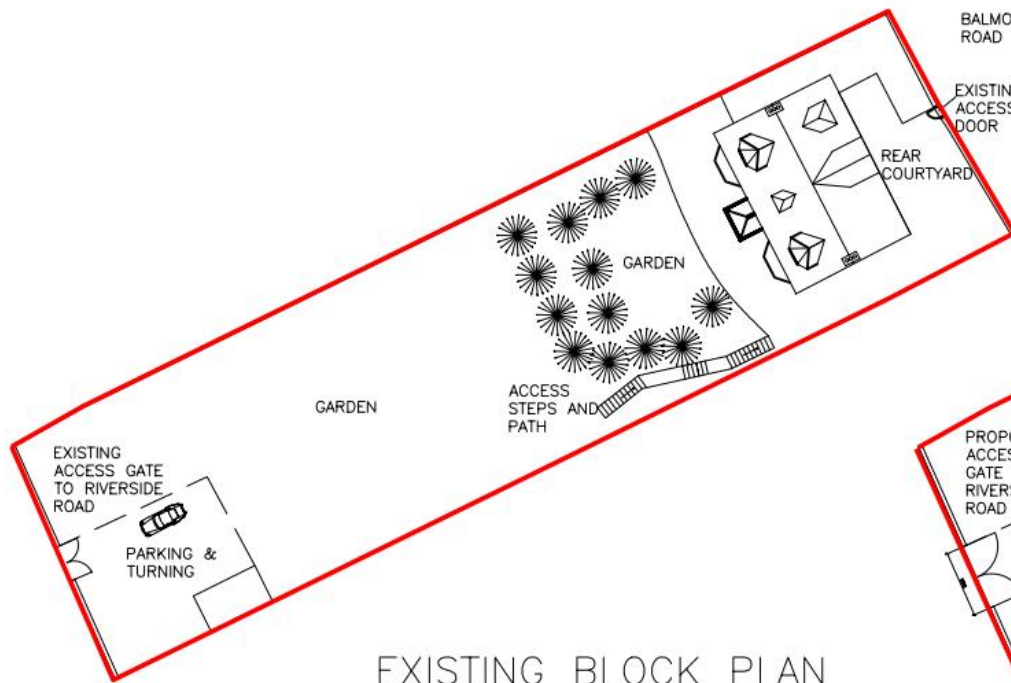

EXISTING BLOCK PLAN

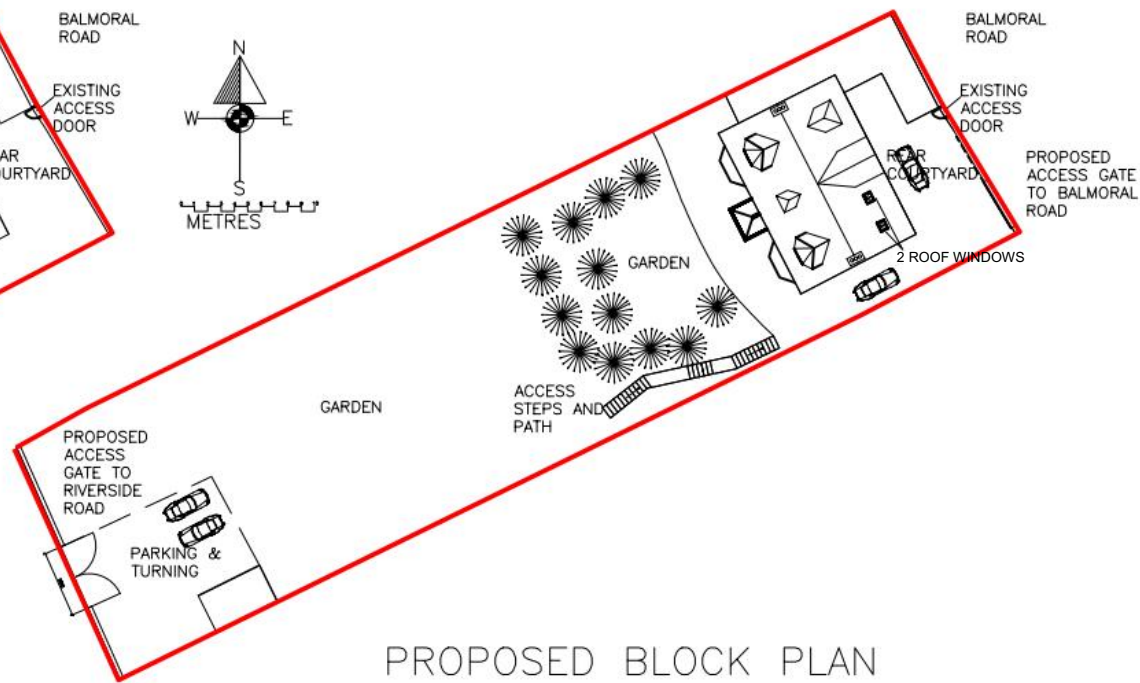
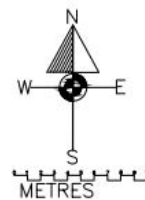

PROPOSED BLOCK PLAN

PROJECT: PROPOSED ALTERATIONS TO MORVEN, BALMORAL ROAD, RATTRAY PH10 7AF

DRAWING REF: EXISTING AND PROPOSED BLOCK PLANS

PAPER SIZE: A1

NORMAN A MACLEOD

namacleod@aol.com

Tel: 07884177328

DATE:FEB 2023

SCALE:1TO200

DRAWING NO:1

REVISION:A

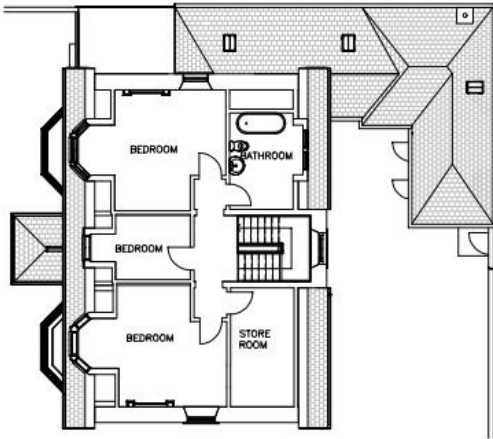

EXISTING FIRST FLOOR PLAN



EXISTING EAST ELEVATION



EXISTING NORTH ELEVATION

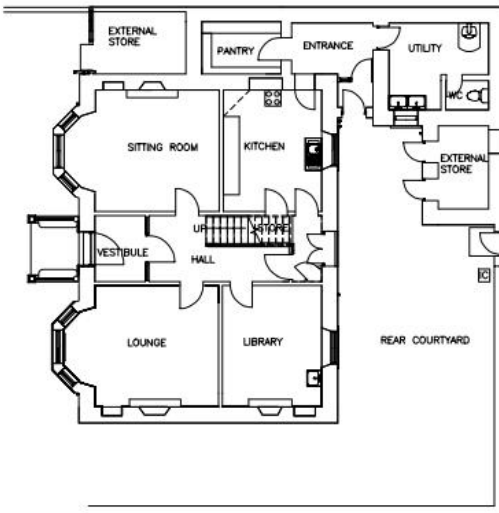

EXISTING WEST ELEVATION



EXISTING SOUTH ELEVATION

PROJECT: PROPOSED ALTERATIONS TO MORVEN, BALMORAL ROAD, RATRAY PH10 7AF

DRAWING REF: EXISTING FLOOR PLANS AND ELEVATIONS

PAPER SIZE: A1

NORMAN A MACLEOD

namacleod@aol.com

Tel: 07884177328

DATE:FEB 2023

SCALE:1TO100

DRAWING NO:2

REVISION:



Imagery ©2023 CNES / Airbus, Maxar Technologies, Map data ©2023 10 m

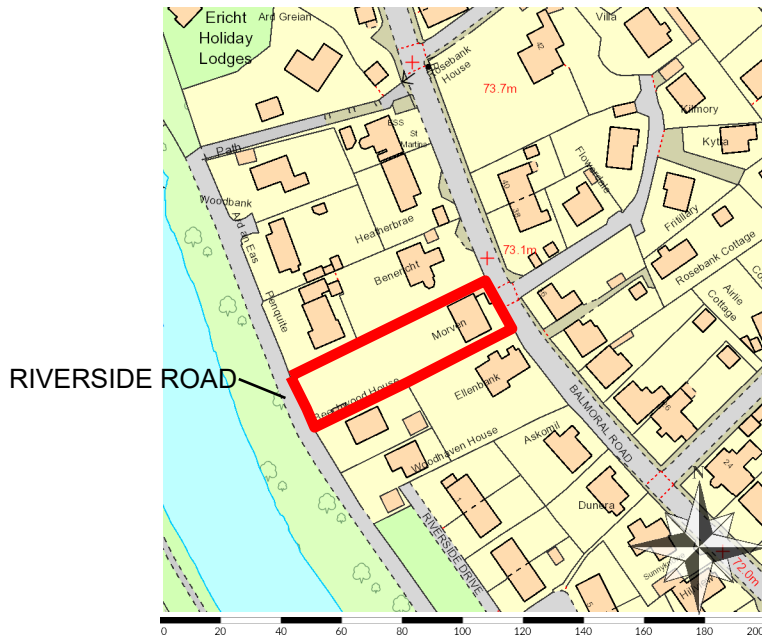

Scale: 1:2500 | Area 4Ha | Grid Reference: 318053,745646 | Paper Size: A4

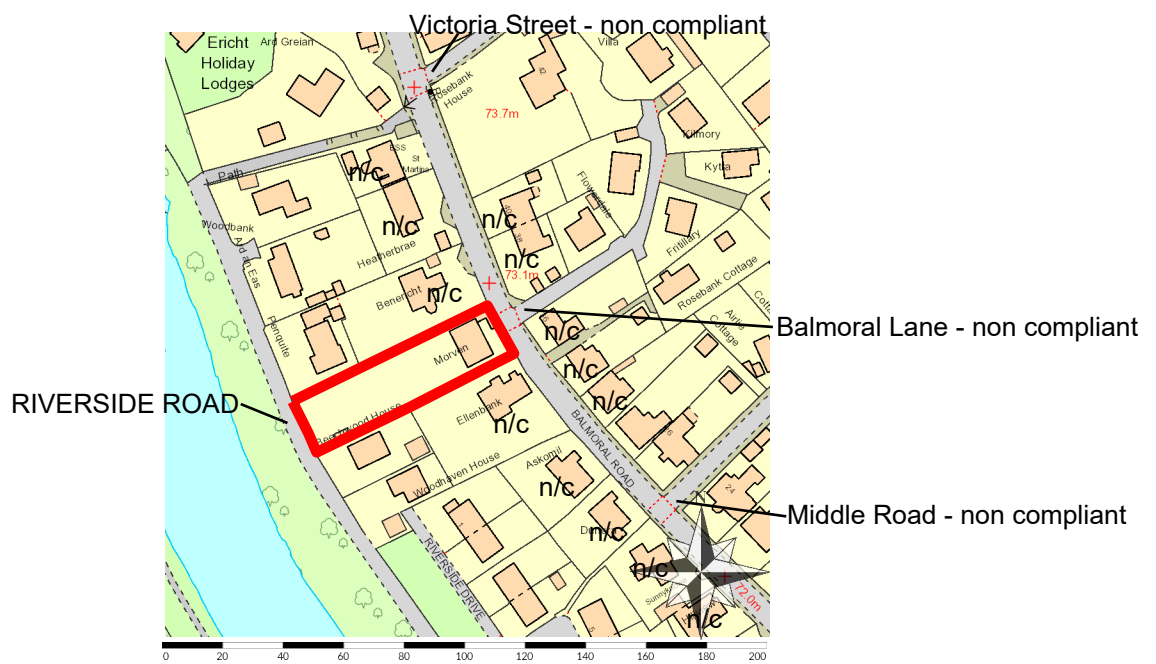

Scale: 1:2500 | Area 4Ha | Grid Reference: 318053,745646 | Paper Size: A4

n/c non-compliant accesses

2.4m back from public road edge with a sight line of 43m

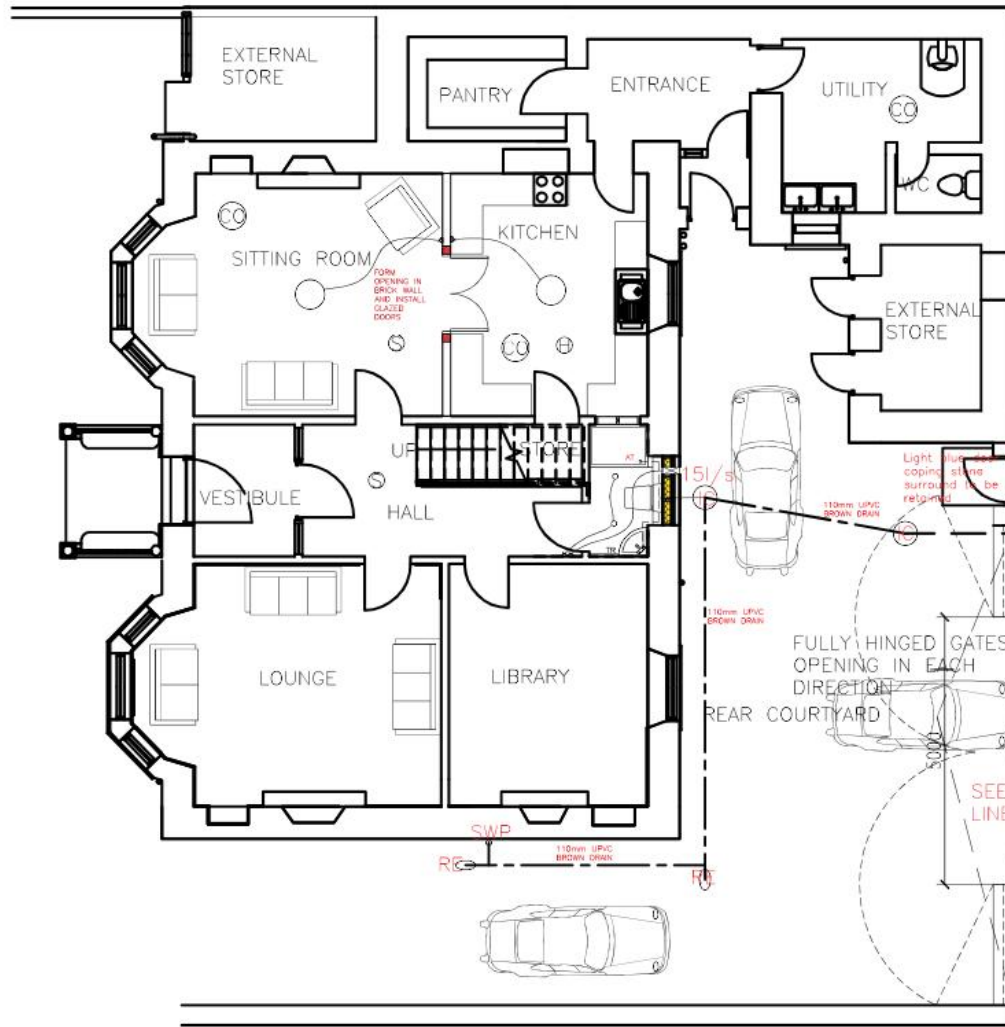

DRAINAGE LEGEND
 RE RODDING EYE
 IC INSPECTION CHAMBER
 SWP SOIL WASTE PIPE
 AT ACCESS TRAP FOR SHOWER
 AAV AIR ADMITTANCE VALVE WITH ACCESS

ELECTRICAL LEGEND
 TWIN 13A SOCKET OUTLET ▲
 LIGHT SWITCH ●
 SMOKE DETECTOR ⊙
 EXTRACTOR FAN ⊠
 HEAT DETECTOR ⊕
 CARBON MONOXIDE DETECTOR ⊙
 PENDANT LIGHT ○
 DOWNLIGHTER ◦

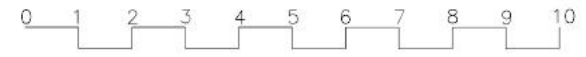

PROPOSED GROUND FLOOR PLAN METRES

PROJECT: PROPOSED ALTERATIONS TO MORVEN, BALMORAL ROAD, RATTRAY PH10 7AF

DRAWING REF: PROPOSED GROUND FLOOR PLAN

PAPER SIZE: A1

NORMAN A MACLEOD

namacleod@aol.com

Tel: 07884177328

DATE: FEB 2023

SCALE: 1 TO 50

DRAWING NO: 3

REVISION: B

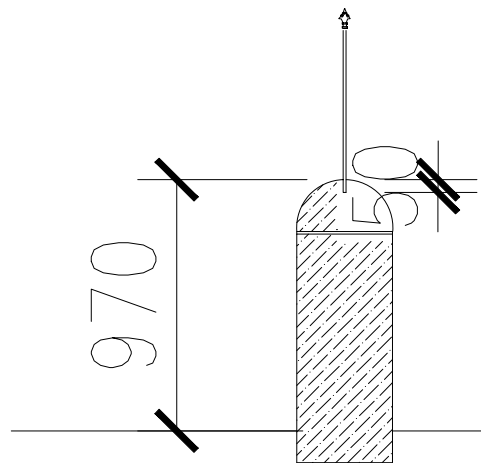

Vertical
Cross-Section
through Stone
Wall and railings

Wall to be rebuilt by a Stonemason.
970mm stone wall including
semi-circular stone cope with light blue
painted wrought iron railings with spars
at 120mm centres up to the height of
the existing boundary wall. Stone
copings to be drilled with wrought iron
railings individually set 50mm into the
crown of the semi-circular coping
stones. Existing natural stone and
coping stones to be salvaged and
re-used and built with lime mortar.
Finials to match those on Riverside
Road.
Ends of coping stones to be cut
and dressed

PROJECT: PROPOSED ALTERATIONS TO MORVEN, BALMORAL ROAD,
RATTRAY PH10 7AF

DRAWING REF: VERTICAL CROSS-SECTION THROUGH STONE WALL
AND RAILING

PAPER SIZE: A1

NORMAN A MACLEOD

namacleod@aol.com

Tel: 07884177328

DATE: APRIL 23

SCALE: 1 TO 10

DRAWING NO: 10

REVISION:

SUPPORTING STATEMENT & PHOTOS

Introduction

Morven is the name of the property that is the subject of the Planning application and is located between Balmoral Road and Riverside Road, Rattray. The building comprises of a 2-storey stone built house and attached single storey ancillary accommodation and outbuilding. All roofs are pitched with a slate finish and all boundary walls are stone.

The property is not listed although it is located within the Blairgowrie and Rattray conservation area.

Proposed Alterations

The proposals include the following:

1. Formation of a slapping between the kitchen and sitting room in the ground storey;
2. Formation of an ensuite and dressing room in the upper storey.
3. Installation of 2No conservation velux roof windows code MK06.
4. Increasing the width of the vehicular access gate to Riverside Road.
5. Formation of a vehicular access gate to Balmoral Road.

Current Accessibility, Vehicular Parking and Vehicular Access Gates

The current means of access to the property is via the rear external courtyard door directly from Balmoral Road and also from Riverside Road via gates having a width of 2.759m. From the Balmoral Road entrance there are 2 steps down into the courtyard and from Riverside Road there are several flights of external steps up to the house.

Additionally, the availability of vehicular parking is limited to the public road on Balmoral Road or Riverside Road which involves traversing the several flights of external steps.

In current terms the house would be classed as 'inaccessible' due to the steps involved.

In order to improve accessibility, it is proposed to increase the existing gate width on Riverside Road to 5m and the formation of a new vehicular access via a new electric sliding gate and a 4m opening in the stone boundary wall on Balmoral Road.

As can be verified on the Google Map all neighbouring properties on the same side of Balmoral Road have vehicular access already installed. Morven has the added advantage that it is located in the centre of a slight bend in Balmoral Road, thereby providing the longest sight lines in both directions.

In terms of turning and parking at the proposed Balmoral Road entrance there is sufficient space to allow 2 vehicles to park and sufficient space within the existing rear courtyard and to the side to allow entering and exit in a forward gear as indicated on the Proposed Ground Floor Plan.

In similarity with some of the neighbouring properties the applicant is proposing to install mirrors to each side of the opening in the stone wall.

With permission to form the vehicular access from Balmoral Road, this would significantly improve accessibility and also provide inclusivity for wheelchair users. This is a current issue for a relative of the applicant and is the principal reason for the submission of the application.

Riverside Road photos







Balmoral Road photos





Conservation Roof Windows

For traditional buildings



CONSERVATION ROOF WINDOWS

When planning dictates that a window of traditional appearance is required, conservation roof windows should be considered. All of our conservation roof windows have the same superior technological features of a VELUX roof window but in a traditional black conservation style.

- Available in either Centre-Pivot or Top-Hung.
- Black external profiles and glazing bar. RAL colour 9005.
- Recessed installation for slate and tiled roofs.
- Top-Hung roof windows listed below are suitable for emergency escape.
- Other sizes and glazing options available – contact VELUX® for further information.

CENTRE-PIVOT

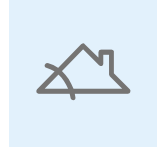

Recessed into slate	20°-90°
Plain tiles	25°-90°
Tiles	15°-90°
Recessed into tiles	20°-90°

TOP-HUNG



Recessed into slate	20°-55°
Plain tiles	25°-55°
Tiles	15°-55°
Recessed into tiles	20°-55°

For roof pitches of 55°-75°, please specify special springs when ordering.

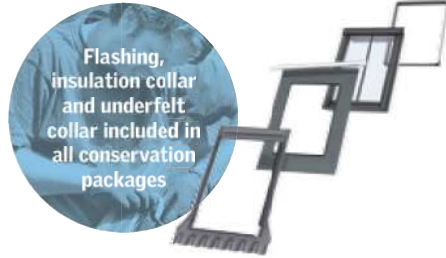

Flashing, insulation collar and underfelt collar included in all conservation packages



ON WINDOWS AND FLASHINGS REGISTER AT WWW.VELUX.CO.UK/ GUARANTEE

Conservation Roof Windows

(Other sizes of conservation roof windows are available subject to lead times.)

External frame size (nominal w x h) cm

Code	Description	CK04	CK06	FK06	MK06	MK08	UK04
------	-------------	------	------	------	------	------	------

Packages include: GGL Centre-Pivot or GPL Top-Hung roof window with glazing bar, flashing, insulation collar (BDX) and underfelt collar (BFX).

Centre-Pivot roof windows, pine. Toughened outer pane (~50). U-value 1.3 W/m²K

GGL SD5N1	GGL 3550 roof window + EDN recessed flashing for slate up to 8mm thick (min 20° roof pitch)	£426	£442	£483	£545	£586	£709
GGL SD5P1	GGL 3550 roof window + EDP flashing for plain tiles up to 14mm thick (min 25° roof pitch)	£383	£398	£435	£495	£533	£648
GGL SD5W1	GGL 3550 roof window + EDW flashing for tiles up to 120mm in profile (min 15° roof pitch)	£398	£414	£452	£512	£551	£670
GGL SD5J1	GGL 3550 roof window + EDJ recessed flashing for tiles up to 90mm in profile (min 20° roof pitch)	£426	£442	£483	£545	£586	£709

Top-Hung roof windows, pine. Toughened outer pane (~50). Suitable for emergency escape. U-value 1.3 W/m²K

GPL SD5N1	GPL 3550 roof window + EDN recessed flashing for slate up to 8mm thick (min 20° roof pitch)	-	-	-	-	£704	-
GPL SD5P1	GPL 3550 roof window + EDP flashing for plain tiles up to 14mm thick (min 25° roof pitch)	-	-	-	-	£651	-
GPL SD5W1	GPL 3550 roof window + EDW flashing for tiles up to 120mm in profile (min 15° roof pitch)	-	-	-	-	£669	-
GPL SD5J1	GPL 3550 roof window + EDJ recessed flashing for tiles up to 90mm in profile (min 20° roof pitch)	-	-	-	-	£704	-

Recessed Flashings

Recessed flashings provide a sleek, streamlined finish as the window is installed deeper into the roof structure (see image), meaning that less of the window protrudes above the roofline. The EDN and EDJ flashings also include a BDX insulation collar and BFX underfelt collar and are recommended by VELUX® for optimum energy efficiency.

Our full range of recessed flashings are available as part of our conservation roof window packages and help you to comply with local conservation requirements.



Grey glazing bars available for standard VELUX roof windows

Optional glazing bars for standard VELUX Roof Windows

The requirements from conservation officers throughout the country differ and the black finish featured on our conservation roof window packages may not be required in your area.

Consult your local conservation officer to see if you can create a traditional appearance by adding a glazing bar to a standard VELUX roof window with grey exterior. This will allow you to take advantage of more window styles and sizes available.

As with our standard conservation roof window, a more traditional appearance can also be achieved by installing the window deeper into the roofline with the use of VELUX recessed flashing kits (pages 38-41). Recessed flashing kits also have the advantage of providing a greater insulating value for a more energy efficient installation.



TO CREATE YOUR GREY CONSERVATION PACKAGE:

- Select your preferred VELUX roof window. This includes white polyurethane, pine and all operating methods (pages 18-23).
- Choose a flashing kit suitable for your specific roof pitch and roofing material – a recessed flashing kit is recommended (pages 38-41).
- Use VELUX installation products for optimum energy efficiency (pages 36-37).
- Add one or more conservation glazing bars in the corresponding size to your window.

Grey glazing bar to match grey exterior (nearest RAL 7043) finish of standard VELUX roof windows.

VELUX® recommend the use of two glazing bars for our wider windows such as SK06, UK04 and UK08.

Optional glazing bars for standard windows	CK02	CK04	MK04	UK04	CK06	FK06	MK06	SK06	MK08	PK08	UK08	PK10
2 glazing bars for SK06, UK04 & UK08	ZGA WK02 0024 £20	ZGA WK04 0024 £22	ZGA WK06 0024 £24	ZGA WK08 0024 £26	ZGA WK10 0024 £28							

► Glazing bars are not available for ~66 and ~62 glazing variants.
► All windows and glazing bars have a delivery time of 2 days.
► Delivery time is in working days from receipt of orders placed before 4pm.

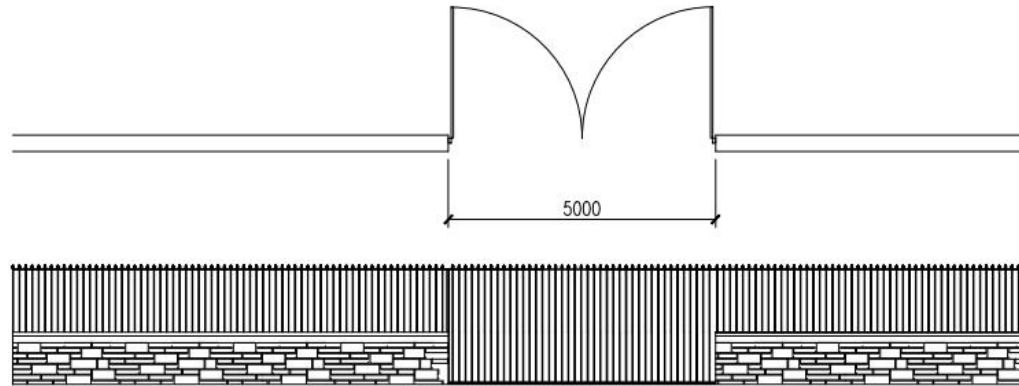

PROPOSED PLAN VIEW & WEST ELEVATION BOUNDARY WALL FACING RIVERSIDE ROAD

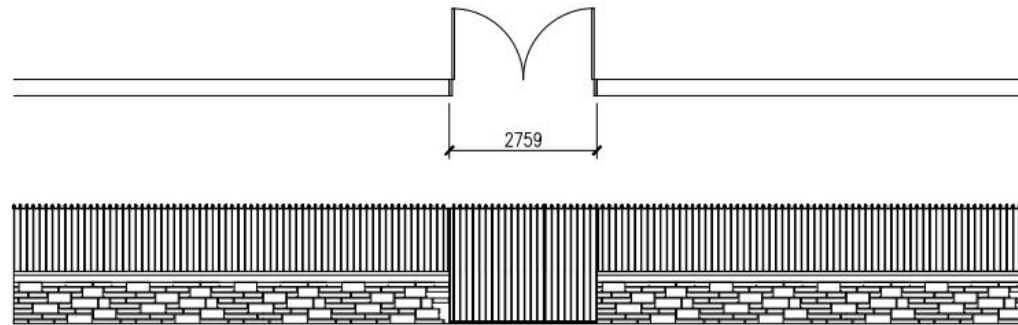

EXISTING PLAN VIEW & WEST ELEVATION BOUNDARY WALL FACING RIVERSIDE ROAD

0 1 2 3 4 5 6 7 8 9 10 METRES

PROJECT: PROPOSED ALTERATIONS TO MORVEN, BALMORAL ROAD,
RATTRAY PH10 7LF
DRAWING REF: PLAN AND ELEVATIONS OF WALL AND GATES
FACING RIVERSIDE ROAD

PAPER SIZE: A1

NORMAN A MACLEOD

namacleod@aol.com

Tel: 07884177328

DATE:FEB 2023

SCALE:1TO50

DRAWING NO:5

REVISION:

